

GT3 Hub - Models # 10-6004, 20-6004

Parts List:

- Hub assembly (1)
- Column sleeve (1)
- w/ set screw & Allen wrench
- Mounting screws (3)
- Grease capsule (2)



FITMENT:

Ford	1964-66	Mustang (w/ Alternator)
Autos	1964-66	Thunderbird
	1965-66	Falcon, Comet, Mercury (All Models)
	1965-67	Fairlane
Ford	1965-66	Ranchero
Trucks	1967	Pick-up
	1967-74	Bronco

NOTICE

Airbag equipped vehicles: GT Performance Products steering wheels and hubs are **not** designed for use on Airbag equipped vehicles. **Due to Safety and Legal reasons**, we do **not** recommend changing, altering or removing the airbag from any vehicle.

PRE-INSTALLATION INSTRUCTIONS

- A) **Read all instructions completely prior to installation process including the supplemental instruction pages that follow this page!**
- B) Align wheels on vehicle straight ahead and disconnect battery.
- C) **Removal of Original or Custom Steering Wheel:** Refer to shop manual for you vehicle or manufacturer of custom steering wheel. **NOTE:** A steering wheel or gear puller may be required.

INSTALLATION INSTRUCTIONS

Once original wheel is removed from column:

- 1) Apply a thin layer of grease to the copper contact ring on back of hub.
- 2) Note "top" marking on hub (2 vertical dimples to indicate "Top"), and position hub onto shaft (Photo A).
- 3) Position column sleeve (with tapered edge towards you) and slide down over hub (Photo A). **Do not adjust or tighten at this time.**

Photo A



- 4) Position steering wheel onto hub (carefully routing wires thru hole on right side of wheel), and install shaft nut (loosely) to hold assembly in position (Photo B).
- 5) Place horn button base with O-ring onto wheel and install using the (3) three mounting screws (Photo B).

Photo B

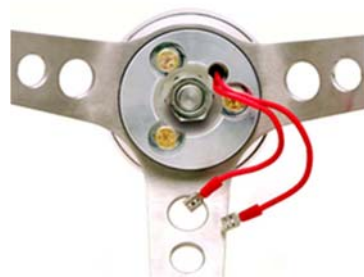

- 6) Tighten shaft nut and mounting screws. **CAUTION:** Do not over tighten mounting screws; this will cause damage to the hub.

TORQUE REQUIREMENTS

Shaft nut: 25 / 30 ft. lbs.
Mounting screws: 10 / 12 ft. lbs.

- 7) Adjust column sleeve so there is a 1/16" to 1/8" gap between column and bottom of sleeve and tighten set screw.
- 8) Connect wires to bottom of horn button and carefully push horn button onto base over O-ring until the horn button is flush with surface of wheel (Photo C). **Note:** If necessary, use a light lubricant or slightly moisten the O-ring to ease installation.

Do not ground horn button wires; this will cause a direct short.

CAUTION: Be careful not to pinch wires when installing horn button onto base.

Photo C



- 9) Reconnect battery and test operation of horn and turn signal cancelling.

NOTE: To Remove Horn Button: Insert small, non-marring plastic blade, or screw driver between notch on bottom of horn button and wheel surface and carefully pry to release.

GT Performance Products LLC Limited Warranty Policy

We warrant our products ninety (90) days from the date of original purchase to be free from defects in material and workmanship. If, during this period, the product fails under normal usage because of a manufacturing defect, then we will replace or repair the item. To obtain repair or replacement under the terms of this warranty, notify us at, GT Performance Products, 2070 Floyd Street, Burbank, CA 91504. Proof of purchase and date of purchase are required to validate warranty.

All implied warranties, including the warranty of merchantability, are limited to the same ninety-day period from date of purchase. We are not liable for any consequential loss or property damage arising from any use of this product. This warranty gives you specific legal rights, and you may also have other rights which vary from state to state. Offer good in U.S.A. and Canada only.

NOTICE

For your own safety, do **not** use this product for any competitive or racing purposes; Racing does not constitute intended usage and therefore makes this warranty void.

Ford Instructions Supplement

Form: 500-1017 R1 (3-25-14)

Beginning in 1966, some Ford vehicles have a small (unused) stub protruding from the end of steering shaft. To allow adequate clearance for GT 3 horn button, it will be necessary to cut-off this portion of the shaft.

You can avoid cutting the stub portion off by using GT Horn button riser # 11-0500 (sold separately)

After removing original wheel and prior to beginning installation, follow the steps below to remove stub:

- 1) Position nut onto shaft and thread down just below stub portion of shaft.
- 2) Shield column so no shavings get into the column.
- 3) Using a hacksaw, cut-off stub portion of shaft flush with threaded portion of shaft.
- 4) Remove shaft nut and proceed with installation.

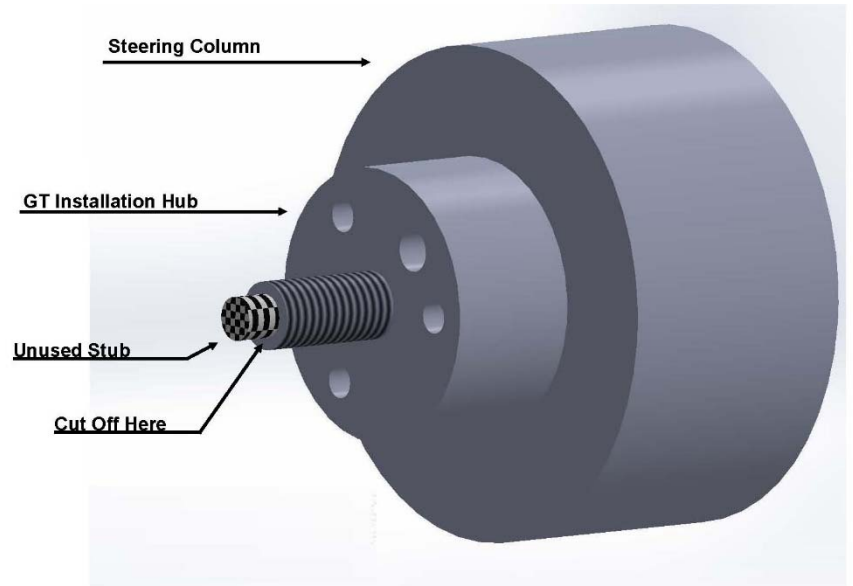

If you do not want to cut the unused portion of shaft consider purchasing our Horn Button Riser Kit. See Below.

GT3 Horn Button Riser Model: 11-0500 Polished 21-0500 Black Form # 500-1053 (3-28-14)

Designed to raise all GT3 horn buttons $\frac{1}{2}$ " to allow for additional shaft clearance (if necessary) or can be used to raise horn button if desired.



1) Spacer and hardware



2) Riser is positioned between wheel and horn button base.



3) Horn button installed with riser.

